

CAST BODY KNIFE GATE VALVES

FIG. 73, STAINLESS STEEL WITH D.I. TOPWORKS - FULL PORT - METAL TO METAL SEAT



Design Features

- ◆ Locking handwheel nut.
- ◆ Provision for lockout lanyard.
- ◆ Heavy gate with wide spaced clevis.
- ◆ Wiper ring in stuffing box assists sealing during both operating and static conditions.
- ◆ TFE impregnated packing for temperature to 450°F/232°C and PH 2-12.
- ◆ Full port one piece cast body with integral cast 210° back-up ring and self cleaning seat pocket.
- ◆ Full lug pattern. Drilled and tapped to class 150 flanges.
- ◆ Easy bolt on conversion to actuator or bevel gear operator.

Designed and tested to conform to MSS-SP81 and TAPPI TIS 405-8 specifications.

Designed to handle dense mixtures of stock and slurries. The shearing action of the knife gate cuts through solids and cleans the seat as it closes. Valve rated for 150psi working pressure.



AMERITEK Industrial Corp.

Tel: 305-663-4448 Fax: 305-663-4458
sales@ameritek.net www.ameritek.net

STAINLESS STEEL KNIFE GATE VALVES

FIG. 73, STAINLESS STEEL - FULL PORT - METAL TO METAL SEAT

FIG 73B - CF8M (316)

FIG 73L - CG8M (317)

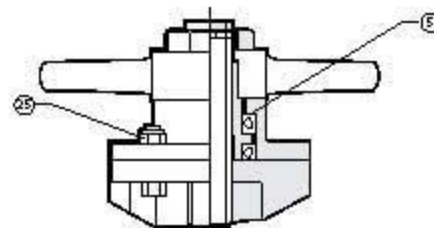
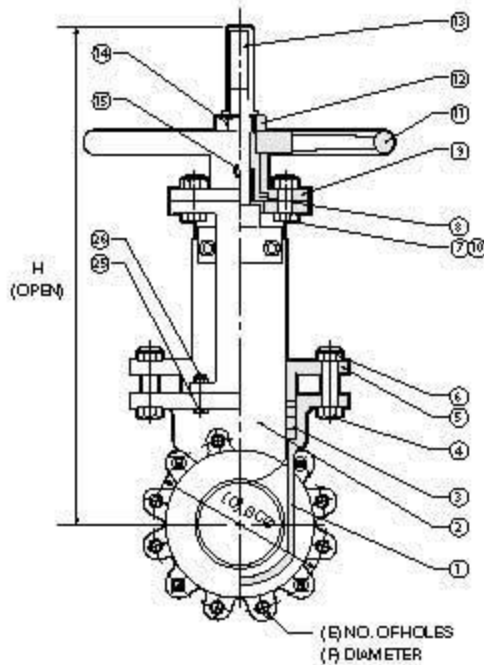
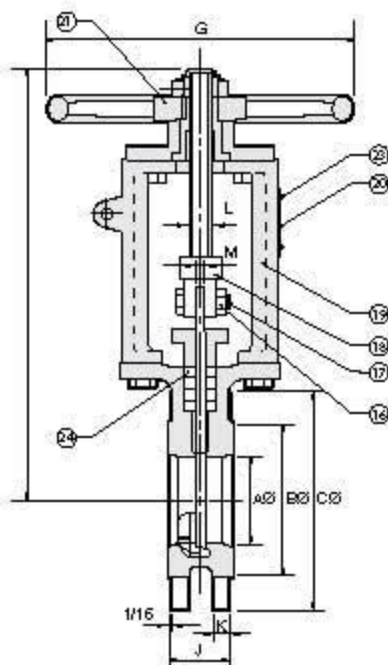

FOR 16" TO 24" TOP WORKS DETAIL

- Handwheel actuator standard.
- Chairwheel, bevel gear, electric or pneumatic actuators are available.
- Valves 30" and larger, or in special alloys like CN7m (Alloy 20), Duplex SS, Hastelloy are available on request.

DIMENSIONS - INCHES

Valve Size	A	B	C	D	E	F	G	h	H	J	K	L	M	Weight lbs
2	2	3 5/8	6	4 3/4	4	5 5/8 - 11	8 1/2	11 7/8	14	1 7/8	1/2	3/4	5/16	31
2 1/2	2 1/2	4 1/8	7	5 1/2	4	5 5/8 - 11	8 1/2	12 5/8	15 1/4	2	1/2	3/4	5/16	35
3	2 7/8	5	7 1/2	6	4	5 5/8 - 11	10	14 5/16	17 5/16	2	1/2	3/4	5/16	38
4	4	6 3/16	9	7 1/2	8	5 5/8 - 11	10	16 13/16	21	2	1/2	3/4	5/16	65
6	6	8 1/2	11	9 1/2	8	5 5/8 - 10	14	20 9/16	26 3/4	2 1/4	5/8	1 1/8	5/16	86
8	8	10 5/8	13 1/2	11 3/4	8	5 5/8 - 10	14	24 3/16	32 3/8	2 3/4	5/8	1 1/8	3/8	140
10	10	12 3/4	16	14 1/4	12	7 5/8 - 9	18	28 7/16	38 3/4	2 3/4	3/4	1 1/8	15/64	187
12	12	15	19	17	12	7 5/8 - 9	18	32 7/16	44 3/4	3	3/4	1 1/8	9/16	225
14	13 1/4	16 1/4	21	18 3/4	12	1 - 8	20	36 9/16	50 1/8	3	13/16	1 1/2	9/16	274
16	15 1/4	18 1/2	23 1/2	21 1/4	16	1 - 8	20	43	58 3/4	3 1/2	7/8	1 1/2	3/4	410
18	17 1/4	21	25	22 3/4	16	1 1/8 - 7	24	47	64 3/4	3 1/2	15/16	1 1/2	3/4	435
20	19 1/4	23	27 1/2	25	20	1 1/8 - 7	24	51 1/8	70 7/8	4 1/2	1	1 1/2	31/64	598
24	23 1/4	27 1/4	32	32	20	1 1/4 - 7	30	68 7/8	82 5/8	4 1/2	1	1 1/2	31/64	771

DIMENSIONS - MILLIMETERS

Valve Size	A	B	C	D	E	F	G	h	H	J	K	L	M	Weight Kg
50	51	92	152	121	4	5 5/8 - 11	216	302	356	48	13	19	8	14
65	63	105	178	140	4	5 5/8 - 11	216	321	387	51	13	19	8	16
80	73	127	191	152	4	5 5/8 - 11	254	364	440	51	13	19	8	17
100	102	157	229	191	8	5 5/8 - 11	254	427	533	51	13	19	8	30
150	152	216	279	241	8	5 5/8 - 10	356	522	679	57	16	29	8	39
200	203	270	343	298	8	5 5/8 - 10	356	614	822	70	16	29	10	64
250	254	324	406	352	12	7 5/8 - 9	457	722	984	70	19	29	12	85
300	305	381	483	432	12	7 5/8 - 9	457	824	1137	76	19	29	15	102
350	337	413	533	476	12	1 - 8	508	929	1273	76	21	38	15	125
400	387	470	597	540	16	1 - 8	508	1092	1492	89	22	38	20	186
450	438	533	635	578	16	1 1/8 - 7	610	1194	1645	89	24	38	20	198
500	489	584	699	635	20	1 1/8 - 7	610	1299	1800	114	25	38	25	272
600	591	692	813	749	20	1 1/4 - 7	762	1495	2099	114	25	38	25	350

Item	Description	73B	73L
1	Body	CF8M	CG8M
2	Gate	316	317
3	Packing	TFE Impregnated	
4	Gland Bolts	Plated Steel	
5	Gland	CF8M	CG8M
6	Gland Nuts	Plated Steel Nylock	
7	Sleeve Housing Bolts	Plated Steel	
8	Stem Sleeve	D980 (Bronze)	
9	Sleeve Housing	Ductile Iron	
10	Housing Lock Washer	Plated Steel	
11	Handwheel	Ductile Iron	
12	Handwheel Nut	Plated Steel	
13	Stem	304	
14	Nut Locking Screw	Plated Steel	
15	Grease Nipple	Plated Steel	
16	Clevis Nuts	Plated Steel Nylock	
17	Clevis bolts	Plated Steel	
18	Clevis	CF8	
19	Yoke	Ductile Iron	
20	Nameplate	Aluminium	
21	Handwheel Key	Steel	
22	Thrust Bearing	Ball	
23	Rivets	Aluminium	
24	Wiper Ring	Hycar	
25	Yoke Bolts	Plated Steel	
26	Yoke Nuts	Plated Steel Nylock	
27	Housing Nuts	Plated Steel Nylock	